



SPECIFICATIONS

- ① Housing Material: Polyamide 66(UL94V-0), Black
- ② Screw: M3.0 Nickel Plated Steel
- ③ Terminals: Tin Plated Brass
- ④ Cover: PC Transparent

Screws Torque: 12 In-Lb

Wire Range: 16~22 AWG

Rated: 20 Amperes.AC300V

Operation Temperature: -55°C~+95°C

Insulation withstands volt: AC2000V min

Insulation resistance: >1000MΩ or more at DC500V

Part Number:

FTB-804-P-

↑ C: With Cover

↑ Pole Size 2~32P

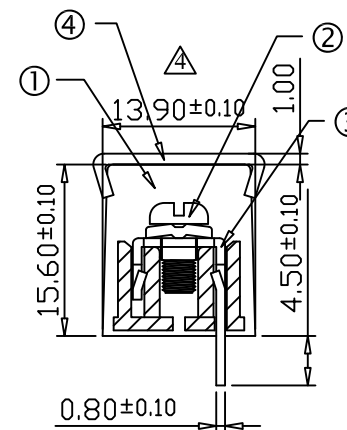
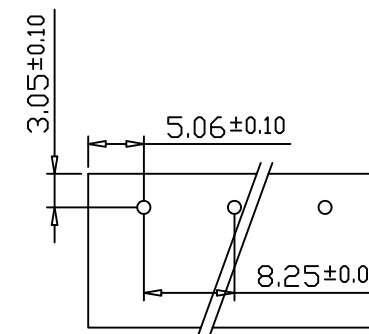
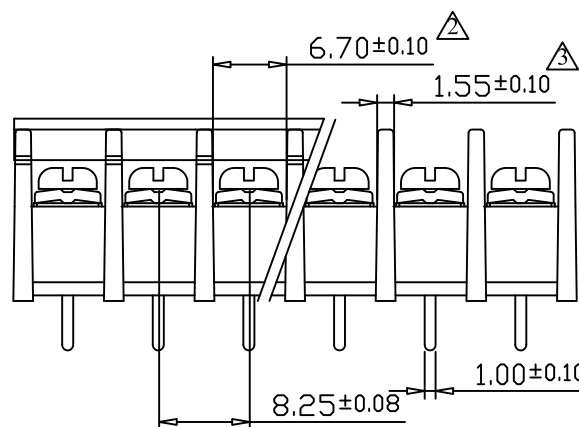
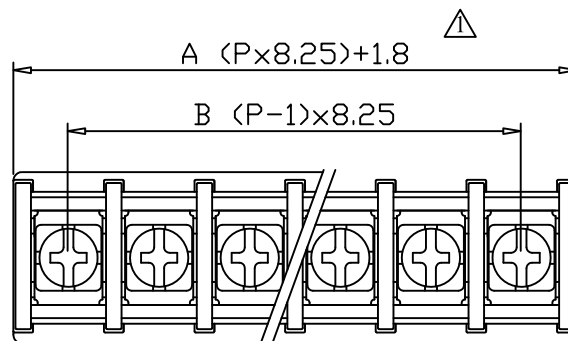

POLE	2	3	4	5	6	7	8	9	10	11	12	13	14	15			
A	18.3	26.55	34.8	43.05	51.3	59.55	67.8	76.05	84.3	92.55	100.8	109.05	117.3	125.55			
B	8.25	16.5	24.75	33	41.25	49.5	57.75	66	74.25	82.5	90.75	99	107.25	115.5			
POLE	16	17	18	19	20	21	22	23	24	25	26	27	28	29	30	31	32
A	134.28	142.05	150.3	158.55	166.8	175.05	183.3	191.55	199.8	208.05	216.3	224.55	232.8	241.05	249.3	257.55	265.8
B	123.75	132	140.25	148.5	156.75	165	173.25	181.5	189.75	198	206.25	214.5	222.75	231	239.25	247.5	255.75

文件發行

2019.11.06

張芳綾



CO/Name	HOW DER ELECTRONIC CO.,LTD	REV.	CONTENT	DATE	POLES	A	B	Drawing	ALLAN	DATE	20160306	DrawingNo	FTB-8082509
P/Name	Barrier type terminal block	△	尺寸修正2.0修改1.8	2017 0809	02P~06P	±0.25	±0.15	DRAWING	APPROVED	DATE		Scale	2:1 (:)
		△	尺寸修正6.6修改6.7	2017 0809	07P~12P	±0.35	±0.20						
		△	尺寸修正1.65修改1.55	2017 0809	13P~18P	±0.40	±0.25	CHECK	DATE		Sheet	1/1	
		△	尺寸修正14修改13.9	2017 0809	19P~24P	±0.45	±0.35						
http://www.howder-tw.com Tel:886-2-2223-1026					25P~30P	±0.50	±0.40			DATE		Unit	mm
E-mail:info@howder-tw.com Fax:886-2-2221-6471													