

# HOW DER

## SPECIFICATIONS

- ① Housing Material: Phenolic , Black
- ② Screw: M4.0 Nickel Plated Steel
- ③ Terminals: Tin Plated Brass

Screws Torque: 9 In-Lb  
 Wire Range: 12~18 WG  
 Rated: 20 Amperes.AC250V  
 Operation Temperature: -55°C~+150°C  
 Insulation withstands volt: AC2000V min  
 Insulation resistance: >1000MΩ or more at DC500V

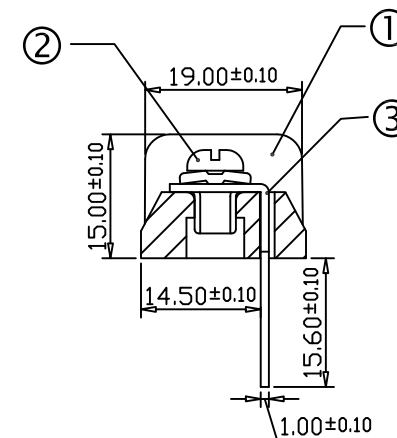
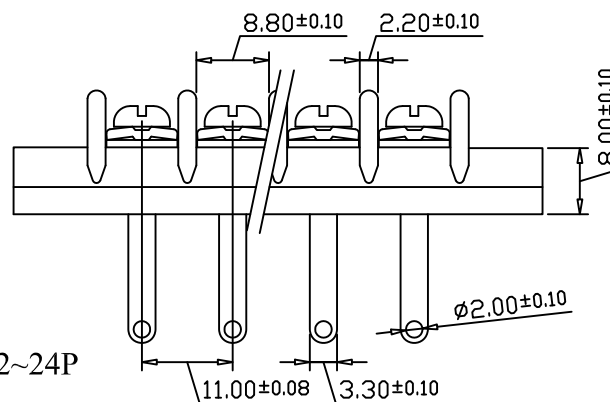
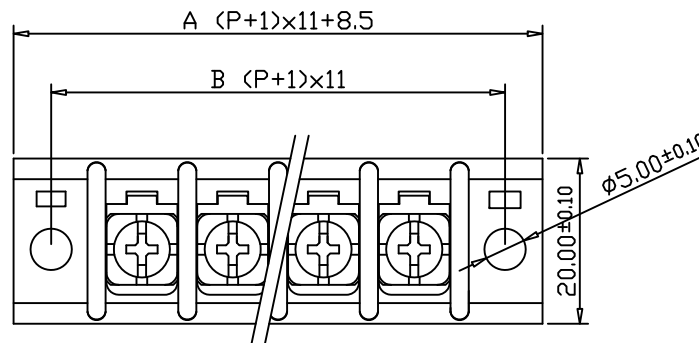

Part Number:

HD-324-PH

Pole Size 02~24P

POLE	<b>02</b>	<b>03</b>	<b>04</b>	<b>05</b>	<b>06</b>	<b>07</b>	<b>08</b>	<b>09</b>	<b>10</b>	<b>11</b>	<b>12</b>	<b>13</b>	<b>14</b>	<b>15</b>
A	41.5	52.5	63.5	74.5	85.5	96.5	107.5	118.5	129.5	140.5	151.5	162.5	173.5	184.5
B	33	44	55	66	77	88	99	110	121	132	143	154	165	176
POLE	<b>16</b>	<b>17</b>	<b>18</b>	<b>19</b>	<b>20</b>	<b>21</b>	<b>22</b>	<b>23</b>	<b>24</b>					
A	195.5	206.5	217.5	228.5	239.5	250.5	261.5	272.5	283.5					
B	187	198	209	220	231	242	253	264	275					

文件發行  
2017.12.08  
黃琦婷

ROHS

CO/Name	HOW DER ELECTRONIC CO.,LTD	REV.	CONTENT	DATE	POLES	A	B	Drawing	DATE	2018/03/12	DrawingNo	HD-3201107	
P/Name	Phenolic type terminal block				02P~06P	±0.30	±0.20	APPROVED	DATE		Scale	2:1( : )	
					07P~12P	±0.35	±0.25		CHECK	DATE		Sheet	1/1
					13P~18P	±0.40	±0.30			DATE		Unit	mm
http://www.howder-tw.com		Tel:02-2223-1026			19P~24P	±0.45	±0.35						
info@howder-tw.com		Fax:02-2221-6471			25P~30P	±0.50	±0.40						