

# HOW DER

## SPECIFICATIONS

- ① Housing Material: Phenolic , Black
- ② Screw: M4.0 Nickel Plated Steel
- ③ Terminals: Tin Plated Brass

Screws Torque: 9 In-Lb  
 Wire Range: 12~18 WG  
 Rated: 20 Amperes.AC250V  
 Operation Temperature: -55°C~+150°C  
 Insulation withstands volt: AC2000V min  
 Insulation resistance: >1000MΩ or more at DC500V

Part Number:

HD-325- PH

Pole Size 02~24P

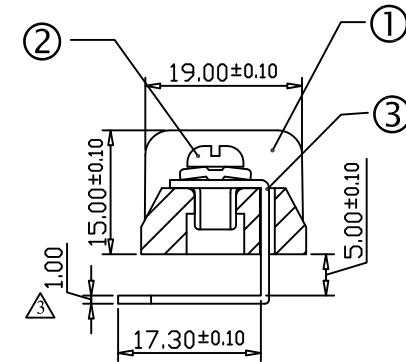
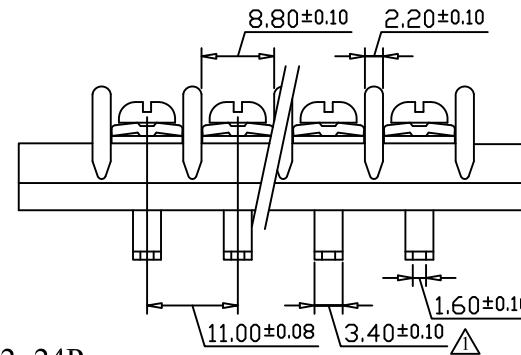
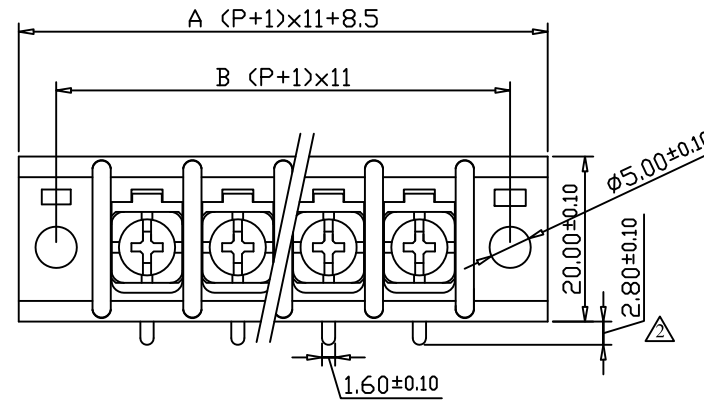

POLE	02	03	04	05	06	07	08	09	10	11	12	13	14	15
A	41.5	52.5	63.5	74.5	85.5	96.5	107.5	118.5	129.5	140.5	151.5	162.5	173.5	184.5
B	33	44	55	66	77	88	99	110	121	132	143	154	165	176
POLE	16	17	18	19	20	21	22	23	24					
A	195.5	206.5	217.5	228.5	239.5	250.5	261.5	272.5	283.5					
B	187	198	209	220	231	242	253	264	275					

文件發行  
2017.12.08  
黃琦婷



CO/Name	HOW DER ELECTRONIC CO.,LTD	REV.	CONTENT	DATE	POLES	A	B	Drawing	DATE	2018/03/12	DrawingNo	HD-3201108
P/Name	Phenolic type terminal block	△	尺寸修改3.5 修改至3.4	2016 1104	02P~06P	±0.30	±0.20	APPROVED	DATE		Scale	2:1( : )
		△	尺寸修改2.6 修改至2.8	2016 1104	07P~12P	±0.35	±0.25		Sheet	1/1		
		△	尺寸修改0.8 修改至1.0	2016 1104	13P~18P	±0.40	±0.30		Unit	mm		
http://www.howder-tw.com      Tel:02-2223-1026					19P~24P	±0.45	±0.35	CHECK	DATE			
info@howder-tw.com      Fax:02-2221-6471					25P~30P	±0.50	±0.40					